

Dreiha
In-Air 2.5

Under-bench AIR CONDITIONING

RV's Motorhomes · Van's



Dreiha In-Air 2.5



VEHICLES UP TO 27 ft



Prepare your vehicle with the built-in air conditioning **In Air 2.5** and you will be able to face the hottest or coldest destinations you can imagine.

The In Air 2.5 has an innovative design. Installs inside the vehicle (*under the bed, sofa, closet, etc*) being **INVISIBLE** since it does not alter the aesthetics or the height of the vehicle. It has a **heat pump**, a **great power for cold** and heat with a **low power consumption**.

In addition, you can **customize air distribution** up to three different points according to the needs of the vehicle.

POWER
COLD HOT

✓ 9000BTU / 9000BTU

VOLTAGE

✓ 115V~/60Hz/1Ph

CONSUMPTION POWER
COLD / HEAT

✓ 995w / 810w

CURRENT COLD / HOT

✓ 8.8A/7.2A

EER/COP

✓ 2.65/3.26

RECOMMENDED AREA

✓ 39 ~ 66 ft²

DIMENSIONS (L*W*H)

✓ 28.9 X 15.7 X 11.7 in

SOUND LEVEL

✓ 38 dB / 48 dB

AIR FLOW (HIGHT SPEED)

✓ 194 ft3/min

WEIGHT

✓ 61 lb

OUTDOOR TEMPERATURE
RANGES

✓ 23°F ~ 109°F

REFRIGERANT TYPE AND
CHARGE

✓ R410a/550g

- **COMPACT** easy to install and maintain.
- System of **HEAT PUMP** for **refrigeration** Y **heating**.
- **EXCELLENT COMFORT** of use with the **remote control** multifunctional or **Control Panel**.
- Designed for vehicles of **UP TO 8 METERS** of length (*optimal 6.5M*).
- **SILENT AIR** with three blowing speeds.
- **INVISIBLE, LOW WEIGHT** and made with **EPP FRAME** that avoids vibrations. It does not alter the height of the vehicle and optimizes its characteristics such as skylights.
- **FLEXIBLE AIR DISTRIBUTION** that can be customized in up to three points to balance comfort.
- **AIR CIRCULATION** with the outside through the floor or wall. (avoiding disturbing other vehicles in the case of the ground)

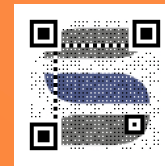

DISTRIBUTION Customizable

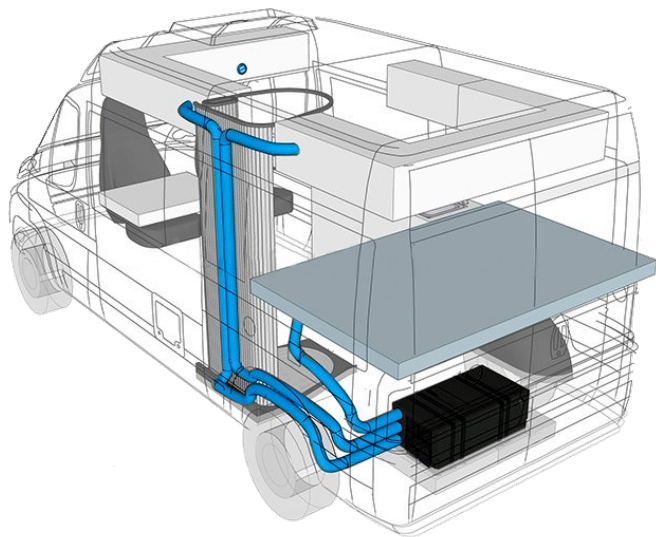

PLANE

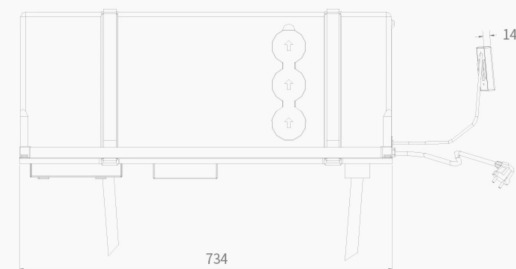
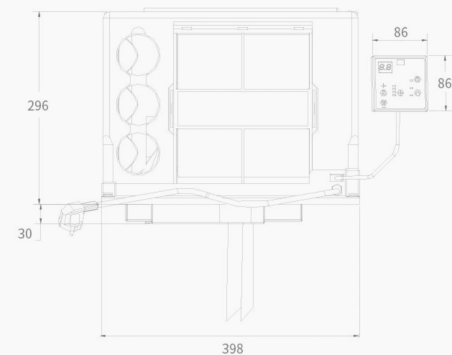

* mm

ACCESSORIES Included



DIMENSIONS

CURVE 90°

2.4 in

REF. NO

9100300015

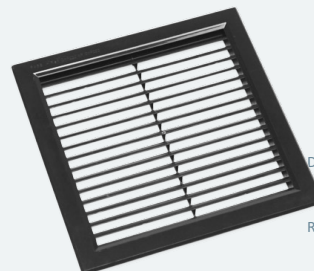

DIMENSIONS

**RECTANGULAR AIR
INLET GRILL**

9.45 x 9.45 in

REF. NO

9100300017